



SUNRISE Fluid Power Inc.

No. 7, Road 12, Industrial Zone, Taichung City 407, Taiwan

Tel: 886-4-2359-1190

Fax: 886-4-2359-3409

sales@sunriseiw.com.tw

www.sunriseiw.com.tw

SUNRISE HYDRAULIC PUNCHING MACHINE

PM-80T/LT/XT

SPARE PARTS LIST

PM-80T/LT/XT

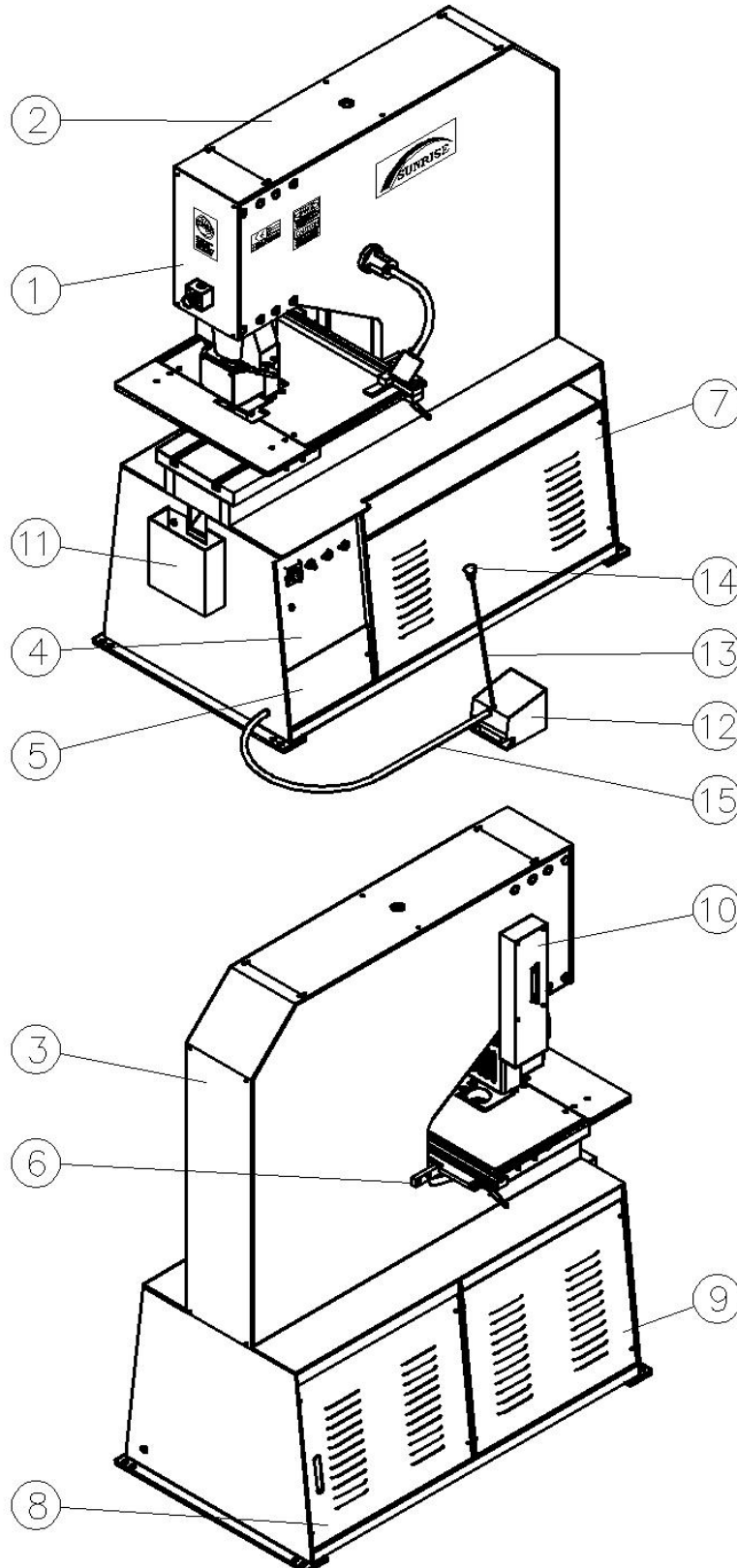

Punching Station Assembly for PM Models

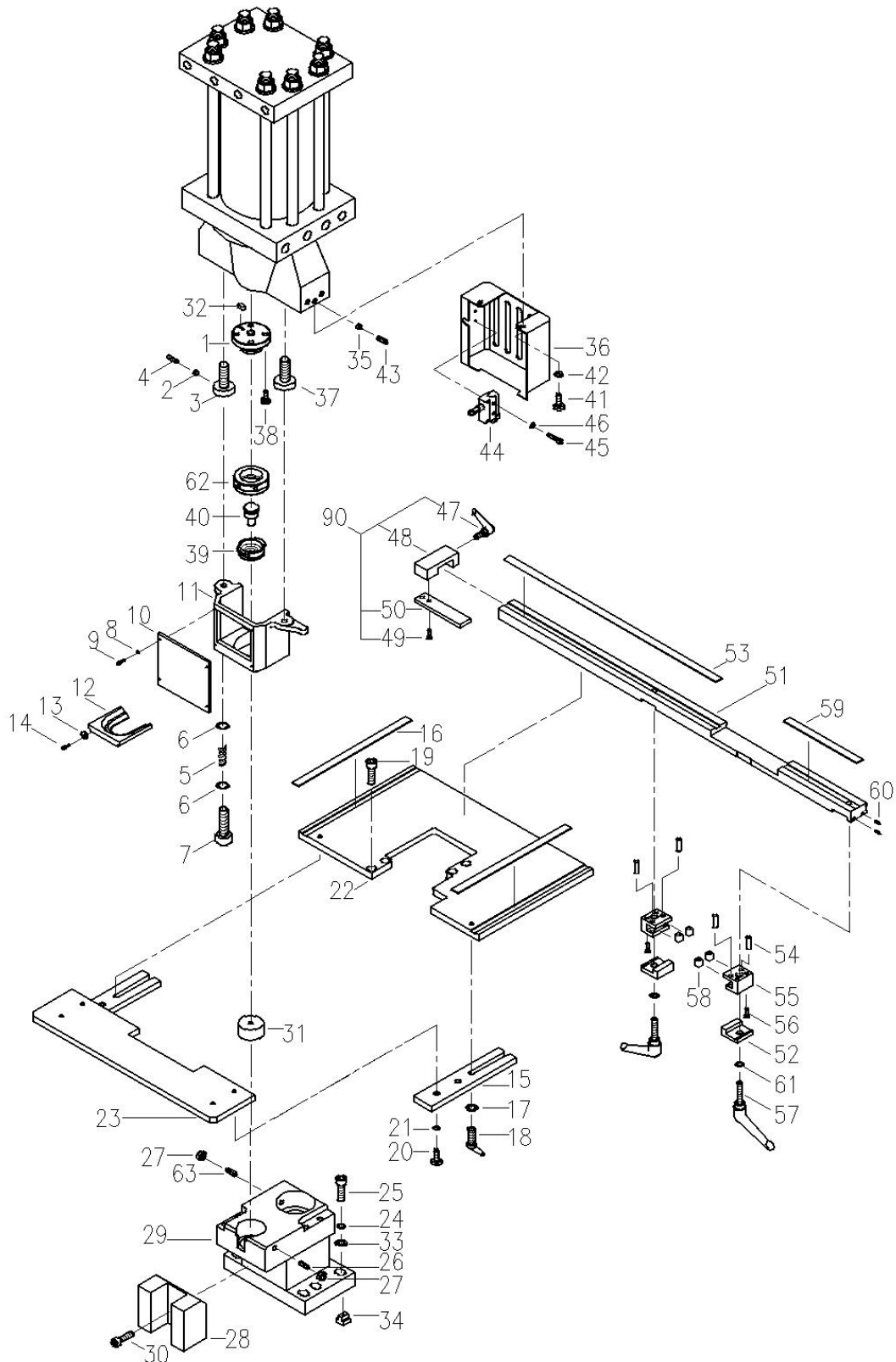



SUNRISE Fluid Power Inc.

No. 7, Road 12, Industrial Zone, Taichung City 407, Taiwan

Tel: 886-4-2359-1190

Fax: 886-4-2359-3409

sales@sunriseiw.com.tw

www.sunriseiw.com.tw

Sunrise Punching Machine Parts List

Model: PM-35/55/80

Part: Punching Station

Date: 02/2012

Item	Part Number	Description	產品名稱	Q'ty	Memo
1	42RTBQA	Retaining Thread	螺紋塊	1	
2	211305090	212211009	Copper Piece	銅墊	1
3		211305005B	Stripper Adj. Screw (2)	剝料器調整螺桿(二)	1
4		56301C0006010	Set Screw M6X10	止付內六角螺柱	1
5		211305006	Stripper Spring	沖孔剝料器彈簧	1
6		56303D00012024045	Flat Washer M12	平墊圈	2
7		56301A0012090	Hex Bolt M12X90	六角承窩頭螺柱	1
8		42STBD	56303A00005	Spring Washer M5	彈簧墊圈
9	56301A0005012		Hex Bolt M5X12	六角承窩頭螺柱	4
10	42STBC002		Stripper Clear Cover	剝料器安全護板	1
11	42STBC006A		Stripper	沖孔剝料器	1
12	42STBC003A-20 42STBC003A-42 42STBC003A-52		Stripper Exchangeable Plate	剝料器底板	1
13	42STBC004		Washer	墊片	2
14	56301I0005008		Cap Screw M5X8	半圓內六孔	2
15	212205005C		Table Connecting Plate	工作板組合塊	2
16	T: 214005110 LT: 214105110 XT: 214205110	T: 213005006A LT: 213105002A XT: 214205005A	Punching Table Ruler 306mm Punching Table Ruler 506mm Punching Table Ruler 756mm	沖孔工作板Y軸標尺	2
17		56303B11012025	Flat Washer M10	平墊圈	2
18		56315404192M1032	Clamp Handle M10X32	萬向把手	2
19		56301A0010020	Hex Bolt M10X20	六角承窩頭螺柱	4
20		56301A0010030	Hex Bolt M10X30	六角承窩頭螺柱	4
21		56303A00010	Spring Washer M10	彈簧墊圈	4
22		T: 214005001F LT: 214105001F XT: 214205001E	Punching Table A (Main)	沖孔工作板(A)	1
23		214005002C	Punching Table B (Front)	沖孔工作板(B)	1
24		56303A00016	Spring Washer M16	彈簧墊圈	6
25		56301A0016060	Hex Bolt M16X60	六角承窩頭螺柱	6
26	56301C7010060	Set Screw M10X60	止付內六角螺柱	1	
27	56302B0110	Nut M10	螺帽	2	
28	43B3DMC	43B1D005A	Die Holder Support	下模座支持塊	1
29		43B3DM900D	Overhang Die Holder (Ø45/Ø80)	雙孔沖孔座	1



SUNRISE Fluid Power Inc.

No. 7, Road 12, Industrial Zone, Taichung City 407, Taiwan

Tel: 886-4-2359-1190

Fax: 886-4-2359-3409

sales@sunriseiw.com.tw

www.sunriseiw.com.tw

Model: PM-35/55/80

Part: Punching Station

Date: 02/2012

Item	Part Number		Description	產品名稱	Q'ty	Memo
30		56301A0012020	Hex Bolt M12X20	六角承窩頭螺栓	1	
31	41RD1		Die	圓孔下模	1	
32	56305D00606018		Locating Key	雙頭圓鍵	1	
33	56303D00016032045		Flat Washer M16	平墊圈	6	
34	211305011		T-Shaped Nut M16	T形螺帽	6	
35	213205010		Copper Piece	銅墊	2	
36	213202034		Stripper Rear Guard	剝料器護板	1	
37	211305004B		Stripper Adj. Screw (1)	剝料器調整螺桿(一)	1	
38	56301A0012025		Hex Bolt M12X25	六角承窩頭螺栓	4	
39	42RSBQ30A 42RSBQM40B 42RSBQM50B		Quick Change Sleeve	快拆上模套環	1	
40	41RP1		Punch	圓孔上模	1	
41	56301A0006010		Hex Bolt M6X10	六角承窩頭螺栓	2	
42	56303A00006		Spring Washer M6	彈簧墊圈	2	
43	56301C0010020		Set Screw M10X20	止付內六角螺栓	2	
44	52411TZ7312		Limit Switch	微動開關	1	
45	56301A0004025		Hex Bolt M4X25	六角承窩頭螺栓	2	
46	56303B10005010		Flat Washer M4	平墊圈	2	
47	214005141	56315404163M1020	Clamp Handle M10X20	萬向把手	1	
48		213205004	Stopper Piece	X軸定位板	1	
49		56301F0006016	Sunk Head Hex Bolt M6X16	皿頭六角承窩螺栓	2	
50		212205007S1	Stopper Piece	沖孔定位塊	1	
51		214005014A	Punching Stopper Guide	Y軸定位板	1	
52		213205020	Stopper Guide Base	定位板固定滑塊	2	
53		213005015	Punching Stopper Guide Ruler 512.5mm	Y軸定位尺標尺(左)	1	
54		56306R0080030	Pin Ø8X30	直銷 Ø8X30	4	
55		213205019	Stopper Y-axis Guide	Y軸定位滑座	2	
56		56301A4006030	Hex Bolt M6X30	六角承窩頭螺栓	4	
57		56315404192M1050	Clamp Handle M10X50	萬向把手	2	
58		56309DTA815	Needle Bearing TA815	滾針軸承 TA815	4	
59		213005006A	Punching Stopper Guide Ruler 297.5mm	Y軸定位尺標尺(右)	1	
60		56301C0005008	Set Screw M5X8	止付內六角螺栓	2	

Limit Switch Adjustment for PM Models

